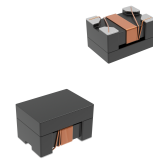

FEATURES

- Winding type realizes small size and low profile
- Prevention of common mode noise at high frequency
- Excellent solderability
- Operating temperature -40~+125 °C (Including self - temperature rise)

APPLICATIONS

- Common mode noise filtering for automotive CAN-BUS and signal line

Explanation of Part Number
ACT 4532L - 101-2P- T F
1 2 3 4 5 6

- ◆ 1:Product Series:Wire Wound Chip Common Mode Filters
- ◆ 2:Dimensions:
- ◆ 3:Number of Lines:2
- ◆ 4:Inductance(μ H): 101=100uH
- ◆ 5:Packing(Tape & Reel)
- ◆ 6:F:Hazardous Substance Free Products

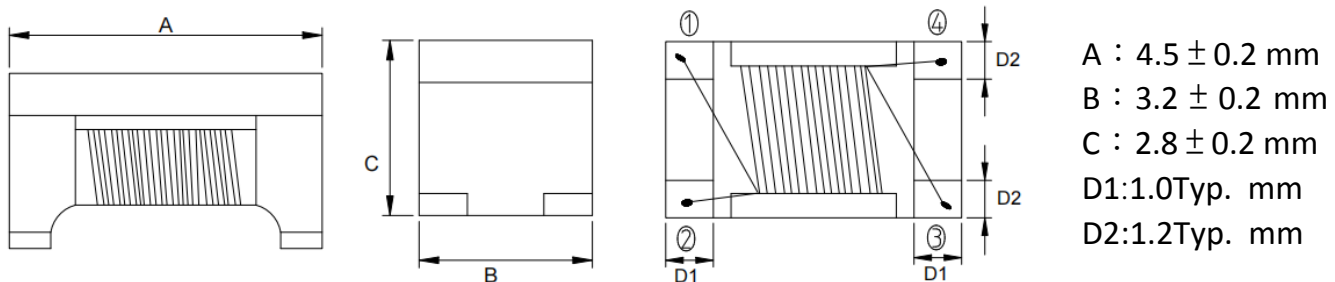
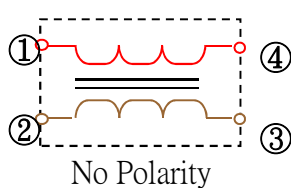
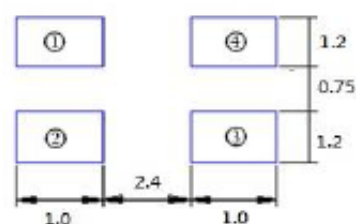
Shapes and Dimensions [mm]

Equivalent circuit

Land Pattern: [mm]

Electrical Characteristics:

Part Number	Common mode Impedance (Ω) [10MHz]		Inductance (μ H)+50/-30% [100kHz/0.1V]	DC Resistance (Ω) max.	Rated Current (mA)	Rated Volt. (Vdc)	IR (M Ω) min.
	min.	typ.					
ACT4532L-110-2P-TF	300 min.	600 typ.	11	0.6	360	50	10
ACT4532L-220-2P-TF	500 min.	1200 typ.	22	1.0	310	50	10
ACT4532L-510-2P-TF	1000 min.	2800 typ.	51	1.0	230	50	10
ACT4532L-101-2P-TF	2000 min.	5800 typ.	100	2.0	200	50	10
ACT4532L-201-2P-TF	5000 min.	14000 typ.	200	4.5	100	50	10

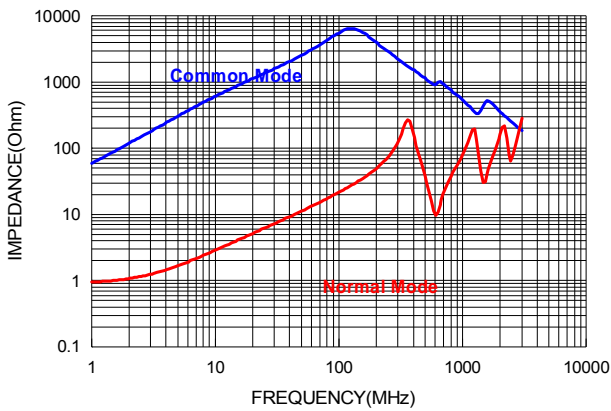
Typical Electrical Characteristics:

ACT4532L-110-2P-TF



ACT4532L-220-2P-TF

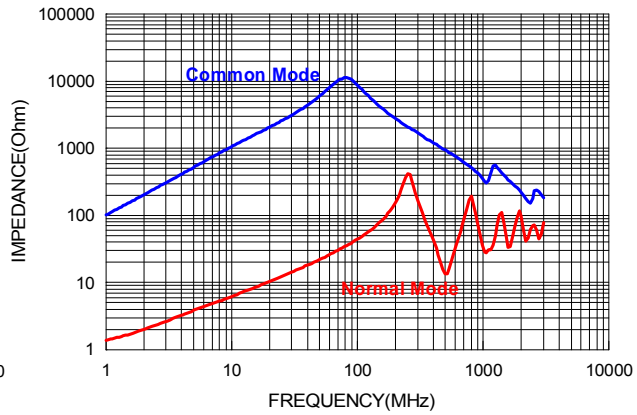

ACT4532L-510-2P-TF

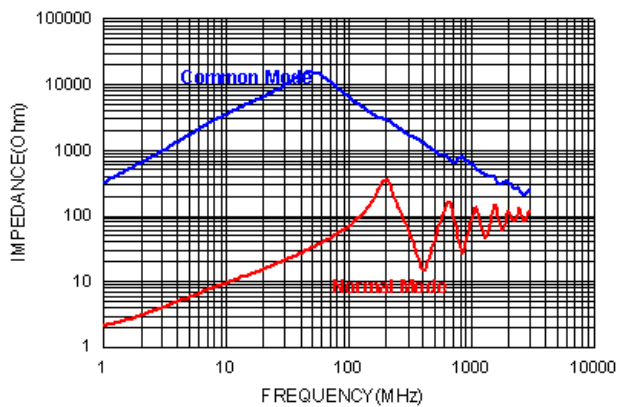

ACT4532L-101-2P-TF

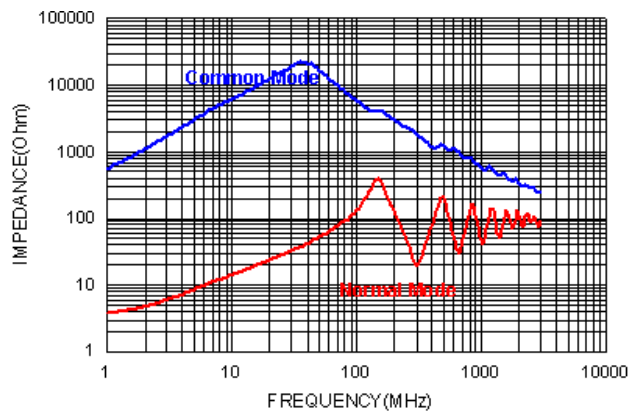

Test Equipment

Inductance

Measured by using Agilent HP4284A Precision LCR Meter.

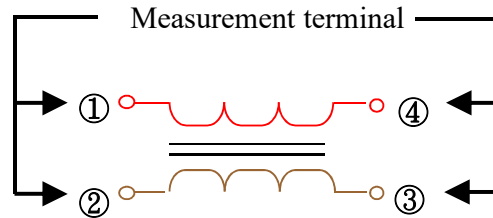

DC Resistance

Measured by using Chroma 16502 mill ohm meter.

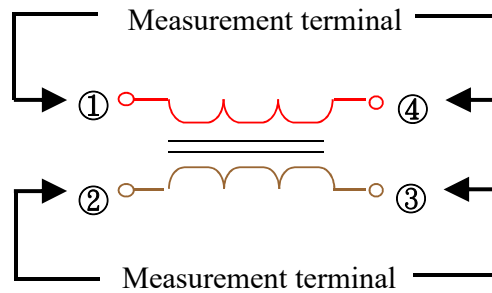

Insulation Resistance

Measured by using Chroma 19073

Measurement voltage : 50v ,Measurement time : 60 sec.

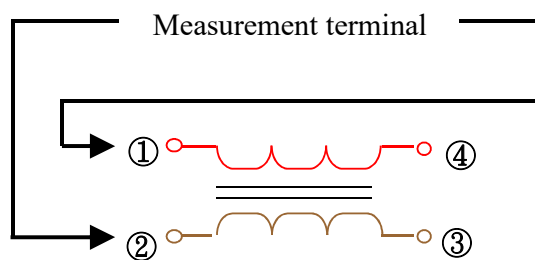

Reliability Test

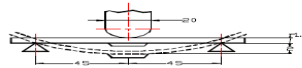
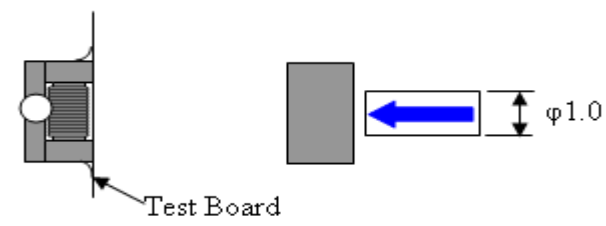
Operating temperature : -40 to +125°C		Storage temp and humidity : 20~25°C ,60%RH max.
Item	Specifications	Test conditions
Board Flex	The forces applied on the right conditions must not damage the terminal electrode and the ferrite.	Test device shall be soldered on the substrate Substrate Dimension: 100x40x1.6mm Deflection: 2.0mm Keeping Time: 60 sec 
Terminal strength	The chip must not damage the terminal electrode and the ferrite.	Appendix 1 Note(AEC-Q200-006):Force of 1.8 kg for 60 seconds. 
Solderability	The electrodes shall be at least 95% covered with new solder coating.	Pre-heating: 150 °C , 1min Solder Composition: Sn/3.0Ag/0.5Cu Solder Temperature: 255±5 °C Immersion Time: 4±1sec
Resistance to Soldering Heat	Appearance:No damage Inductance change shall be within ±20%.	Pre-heating: 150°C , 1min Solder Composition: Sn/Ag3.0/Cu0.5 Solder Temperature: 255±5°C Immersion Time: 10±1sec
Resistance to Solvents	There must be no change in appearance or obliteration of marking.	Inductors must withstand 6 minutes of alcohol or water.
Mechanical Shock	The forces applied on the right conditions must not damage the terminal electrode and the ferrite.	Pulse shape:Half-sine waveform Impact acceleration:100g Pulse duration : 6ms Number of shocks: 18 shocks (3 shocks for each face) Orientation:Bottom,top,left,right,front and rear faces

Item	Specifications	Test conditions
Vibration	Appearance:No damage Inductance change shall be within $\pm 20\%$.	Vibration waveform: Sine waveform Vibration frequency: 10Hz~2000Hz Vibration acceleration: 5g Sweep rate: 0.764386otcave/minute Duration of test: 12 cycles each of 3 orientations 20 minutes for each cycle Vibration axes: X, Y & Z
High Temperature Exposure (Storage)	Appearance:No damage (for microscope of MEIJI WF10X/22) Inductance change shall be within $\pm 30\%$.	Temperature: $125\pm 3^{\circ}\text{C}$ Time:1000hrs Measured after exposure in the room condition for 24hrs
Biased Humidity		Temperature: $85\pm 2^{\circ}\text{C}$ Relative Humidity: 85% Time: 1000hrs Measured after exposure in the room condition for 24hrs
Operational Life		Temperature : $125\pm 2^{\circ}\text{C}$ Applieend Current : Rated Current Time : 1000 ± 24 hrs Measured after exposure in the room condition for 24 hrs
Temperature Cycling		Total cycles: 1000 cycles Temperature Cycling Test Conditions : -40 to $+125^{\circ}\text{C}$ Soak Mode Condition : 30 minutes Measured after exposure in the room condition for 24hrs

Reel Dimension & Tape Dimension

Reel Dimensions

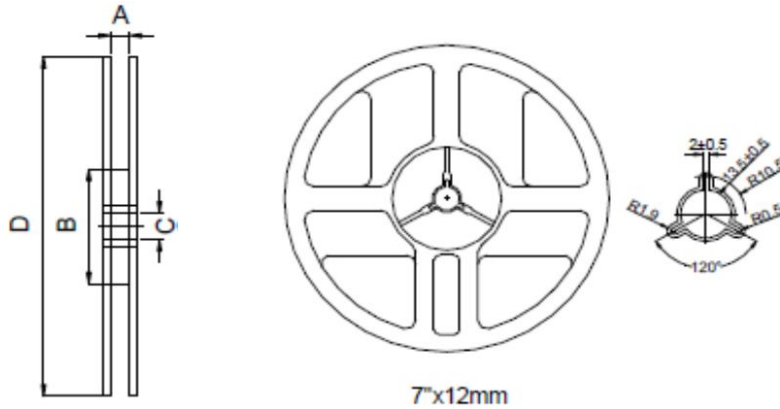

Unit: mm

A	B	C	D
13.2±0.5	60±2	13±0.5	180±2

Tape Dimensions

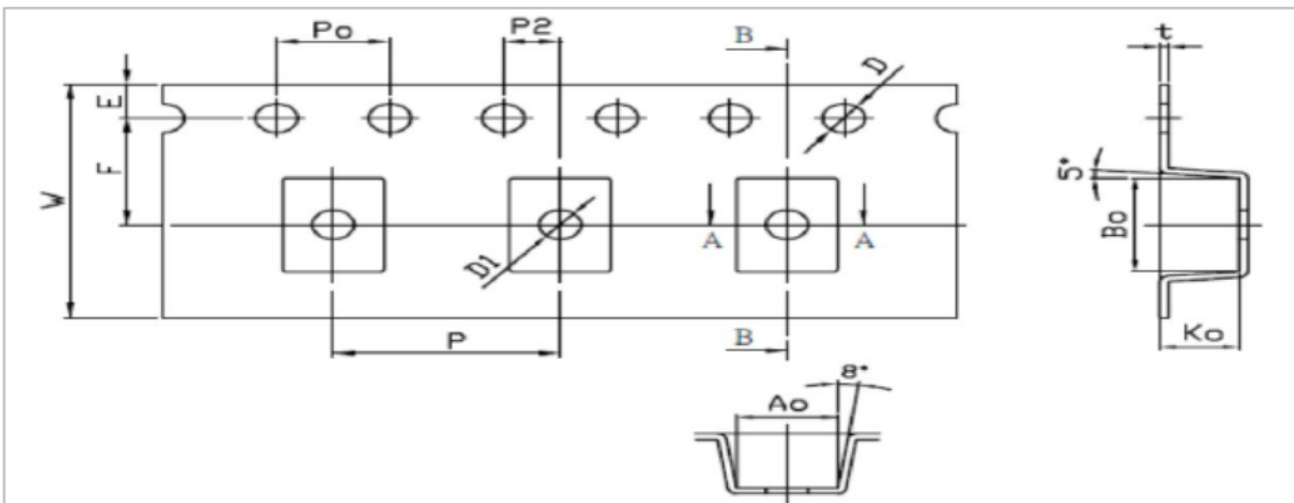

Symbol	W	P	E	F	P2	D	D1	Po	10Po
Dimension	12.00	8.00	1.75	5.50	2.00	1.50	1.50	4.00	40.00
SPEC.	±0.1	±0.1	±0.1	±0.05	±0.05	+0.10 -0.00	±0.1	±0.1	±0.2
Symbol	Ao	Bo	Ko	t					
Dimension	3.57	4.80	2.80	0.30					
SPEC.	±0.1	±0.1	±0.1	±0.05					

Packaging Quantity:500PCS/Reel

Soldering Conditions

**Figure 1.
Re-flow
Soldering (Lead
Free)**

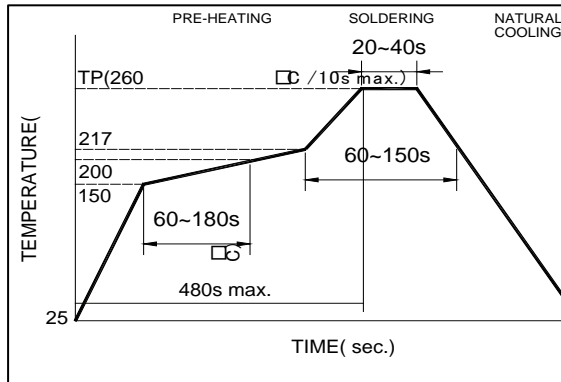

Note:

- Preheat circuit and products to 150°C
- 260°C tip temperature (max)
- Reflow times: no more than 2 times
- Solder paste thickness: the best 0.08mm is ,but max is 0.1mm

**Figure 2.
Wave Soldering**

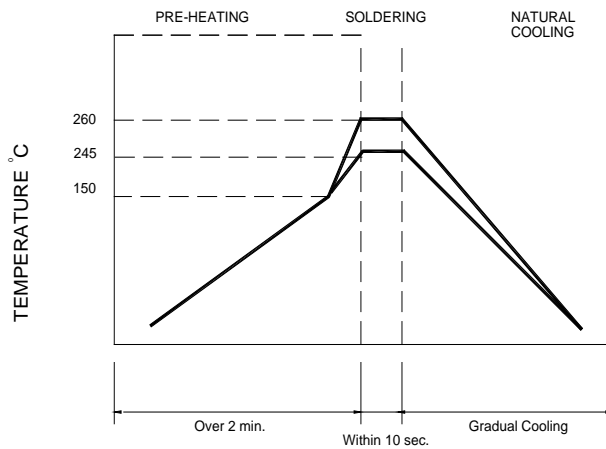

Note :

- Never contact the ceramic with the iron tip
- 1.0mm tip diameter (max)

**Figure 3.
Hand Soldering**

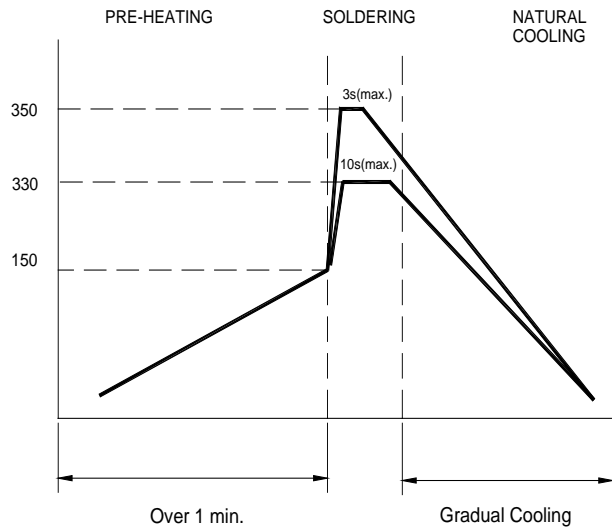

Note:

- Use a 20 watt soldering iron with tip diameter of 1.0mm
- Limit soldering time to 3 sec.