

MCMB-1365 Series

High Current Molded Power Inductors

FEATURES

- Powder iron core material
- Magnetically shielded, low EMI
- High current carrying capacity, Low core losses
- Frequency range up to 3MHz
- Operate temperature range $-40^{\circ}\text{C} \sim +125^{\circ}\text{C}$ (Including self temp. rise)
- RoHS compliant

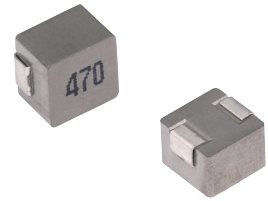

APPLICATIONS

- Voltage Regulator Module (VRM)
- Multi-phase regulators
- Point-of-load modules
- Smart phone POL modules
- SSD modules
- Notebook regulators
- Battery power systems
- Graphics cards
- Data networking and storage systems

Explanation of Part Number

MCMB -1365 -1R0 M T ZP01

1 2 3 4 5 6

- ◆ 1:Product Series:Metal Alloy Molding Power Inductor
- ◆ 2:Dimensions:
- ◆ 3: Initial inductance value: 1R0 = 1.0uH
- ◆ 4:Tolerance of Inductance:M:±20%
- ◆ 5:Packing:Tape Carrier Package

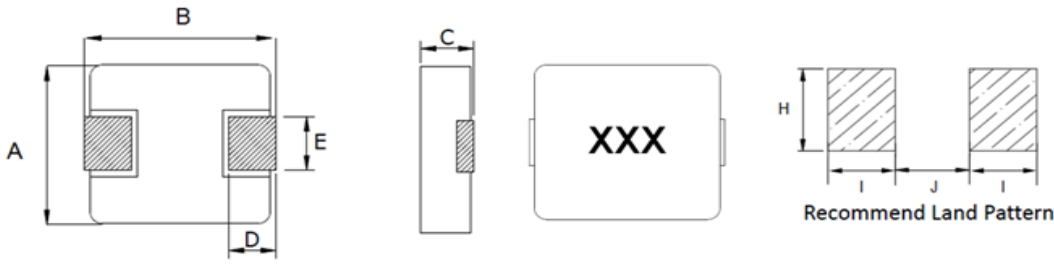
Dimensions: [mm]

Series	A	B	C	D	E	I Typ.	J Typ.	H Typ.
MCMB-1365	12.6±0.3	13.45±0.35	6.5Max.	2.0±0.5	5.0±0.3	3.25	8.0	5.5

Electrical Properties:

Part Number	Inductance	DC Resistance	Saturation Current		Heat Rating Current	
	@100KHz, 1V	Max.	Max.	Typ.	Max.	Typ.
Units	μH	mΩ	A		A	
Symbol	L	DCR	Isat		Irms	
MCMB-1365-4R7MT	4.7±20%	8.5	-	24.0	-	16.0
MCMB-1365-5R6MT	5.6±20%	10.5	-	22.5	-	14.0
MCMB-1365-6R8MT	6.8±20%	12	-	19.0	-	13.0
MCMB-1365-8R2MT	8.2±20%	14	-	16.0	-	12.0
MCMB-1365-100MT	10±20%	16.5	-	15.0	-	11.0
MCMB-1365-150MT	15±20%	26	-	11.0	-	9.50
MCMB-1365-220MT	22±20%	36	-	9.00	-	8.00
MCMB-1365-330MT	33±20%	65	-	8.00	-	6.50
MCMB-1365-470MT	47±20%	70	-	6.80	-	5.50
MCMB-1365-680MT	68±20%	120	-	5.20	-	4.80
MCMB-1365-820MT	82±20%	135	-	4.50	-	4.00
MCMB-1365-101MT	100±20%	170	-	4.00	-	3.50

Notes:

- All test data is referenced to 20 °C ambient
- Irms(A):DC current (A) that will cause an approximate ΔT of 40 °C(reference ambient temperature is 20°C)
- Isat(A):DC current (A) that will cause L0 to drop approximately 30 %
- The part temperature (ambient + temp rise) should not exceed 125 °C under worst case operating conditions. Circuit design, component placement, PWB trace size and thickness, airflow and other cooling provisions all affect the part temperature. Part temperature should be verified in the end application.
- Absolute maximum voltage 30V

Typical Performance Curve:

MCMB-1365-4R7MT

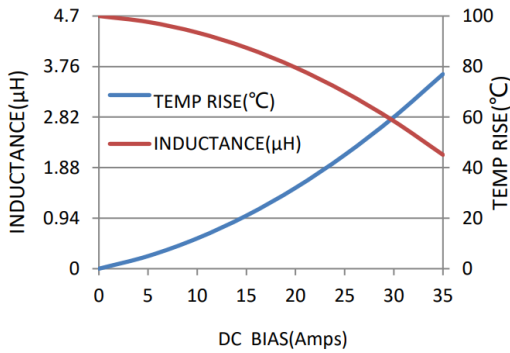

MCMB-1365-5R6MT

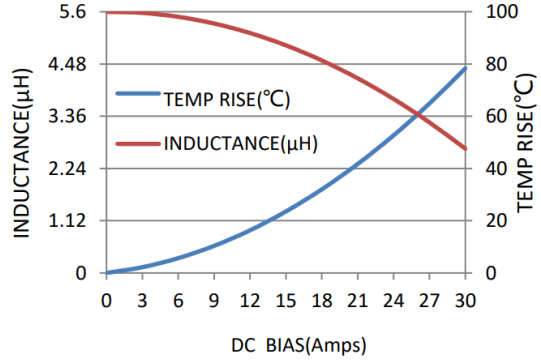

MCMB-1365-6R8MT

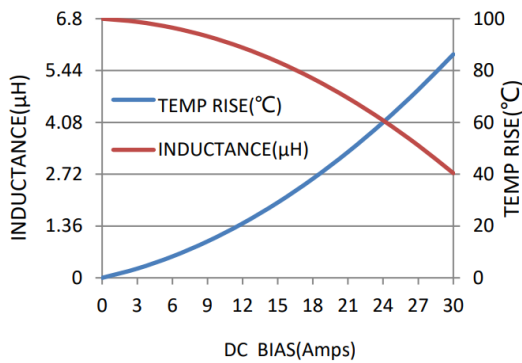

MCMB-1365-100MT

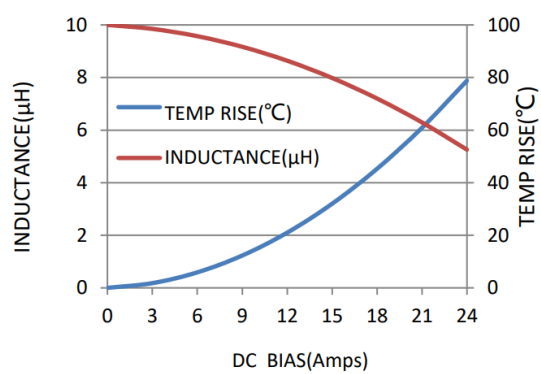

MCMB-1365-150MT

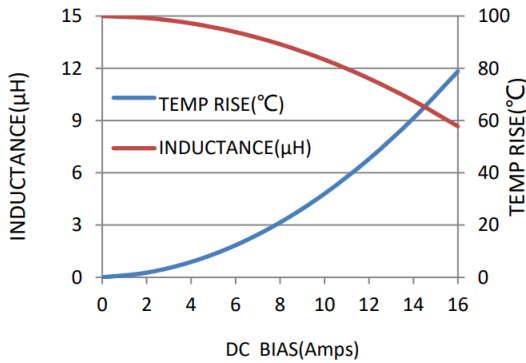

MCMB-1365-220MT

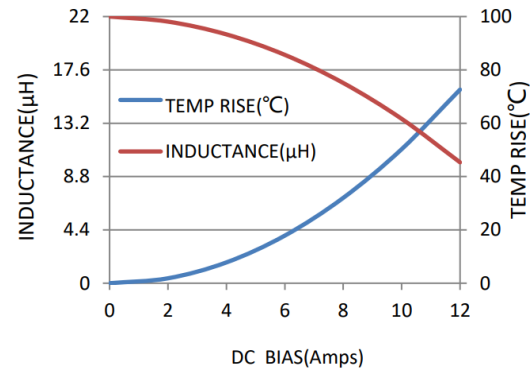

MCMB-1365-330MT

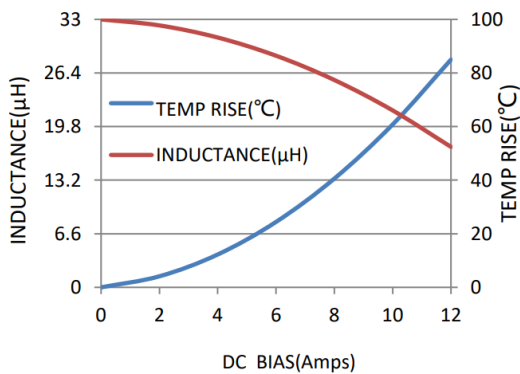

MCMB-1365-470MT

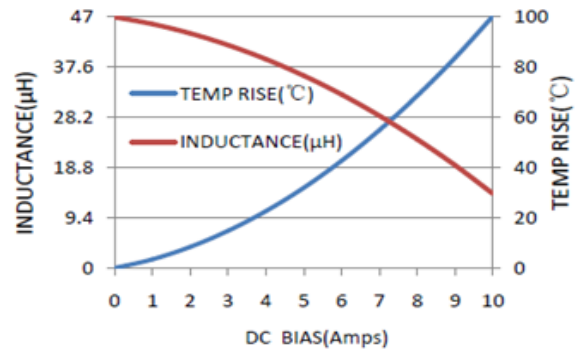

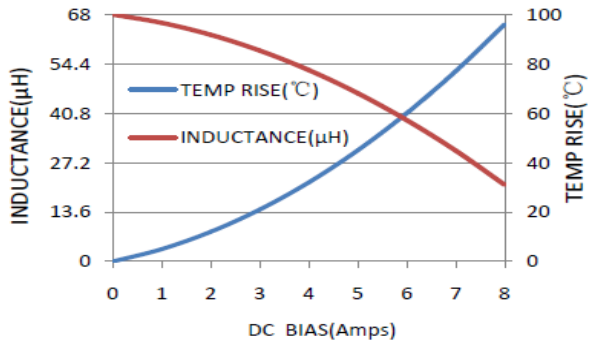
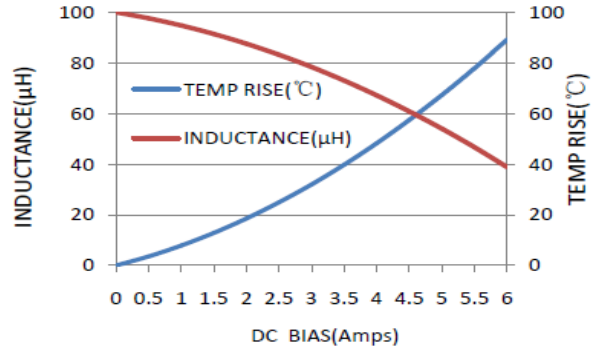
MCMB-1365-680MT

MCMB-1365-101MT

Reliability and Test Condition

Mechanical Reliability		
Item	Specification and Requirement	Test Method
Solderability	The surface of terminal immersed shall be minimum of 95% covered with a new coating of solder	Solder heat proof: 1. Preheating: 160 ± 10 °C 2. Retention time: 245 ± 5 °C for 2 ± 0.5 seconds
Vibration	Inductance change: Within $\pm 10\%$ Without mechanical damage such as break	1. Vibration frequency: (10 Hz to 55 Hz to 10Hz) in 60 seconds as a period 2. Vibration time: Period cycled for 2 hours in each of 3 mutual perpendicular directions. 3. Amplitude: 1.5 mm max.
Shock	Inductance change: Within $\pm 10\%$ Without mechanical damage such as break	1. Peak value: 100 G 2. Duration of pulse: 11ms 3. 3 times in each positive and negative direction of 3 mutual perpendicular directions
Endurance Reliability		
Item	Specification and Requirement	Test Method
Thermal Shock	Inductance change: Within $\pm 10\%$ Without distinct damage in appearance	1. Repeat 100 cycles as follow: (-55 ± 2 °C; 30 ± 3 min) →(Room temp., 5 min) → ($+125 \pm 2$ °C, 30 ± 3 min) → (Room temp., 5 min) 2. Recovery: $48 + 4 / -0$ hours of recovery under the standard condition after the test.
High Temperature Resistance	Inductance change: Within $\pm 10\%$ Without distinct damage in appearance	1. Environment condition: 85 ± 2 °C Applied Current: Rated current 2. Duration: $1000 + 4 / -0$ hours
Humidity Resistance	Inductance change: Within $\pm 10\%$ Without distinct damage in appearance	1. Environment condition: 60 ± 2 °C Humidity: 90–95% Applied Current: Rated current 2. Duration: $1000 + 4 / -0$ hours
Low Temperature Store	Inductance change: Within $\pm 10\%$ Without distinct damage in appearance	Store temperature: -55 ± 2 °C, $1000 + 4 / -0$ hours
High Temperature Store	Inductance change: Within $\pm 10\%$ Without distinct damage in appearance	Store temperature: $+125 \pm 2$ °C, $1000 + 4 / -0$ hours

● Recommended Soldering Technologies

(1) Re-flowing Profile

Preheat condition: 150 ~200°C/60~180sec.

Allowed time above 217°C: 80~120sec.

Max temp: 260°C

Max time at max temp: 10 sec.

Solder paste: Sn/3.0Ag/0.5Cu

Allowed Reflow time: 2x max

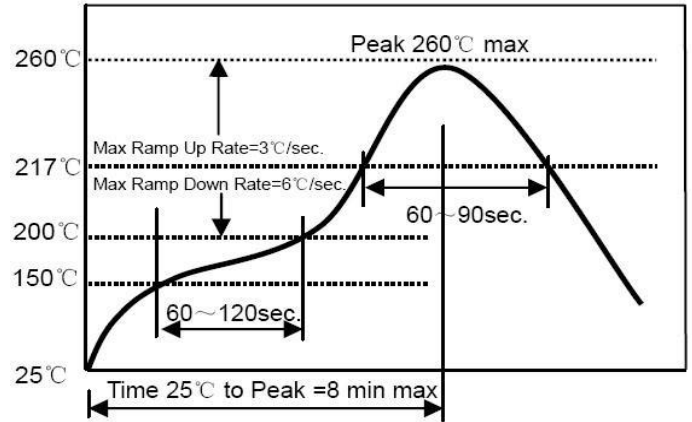

(2) Iron Soldering Profile

Iron soldering power: Max.

30W Pre-heating: 150°C/60sec.

Soldering time: 3sec. Max.

Solder paste: Sn/3.0Ag/0.5Cu

Max.1 times for iron soldering

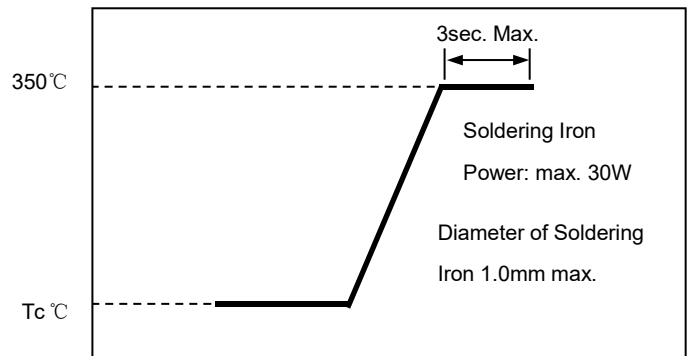

Packaging

- Tape Packaging Dimensions (UNIT:mm)

Peel force of top covert MCMB

The peel speed shall be about 300mm/minute

The peel force of top covert MPIF shall be between 0.1 to 1.3

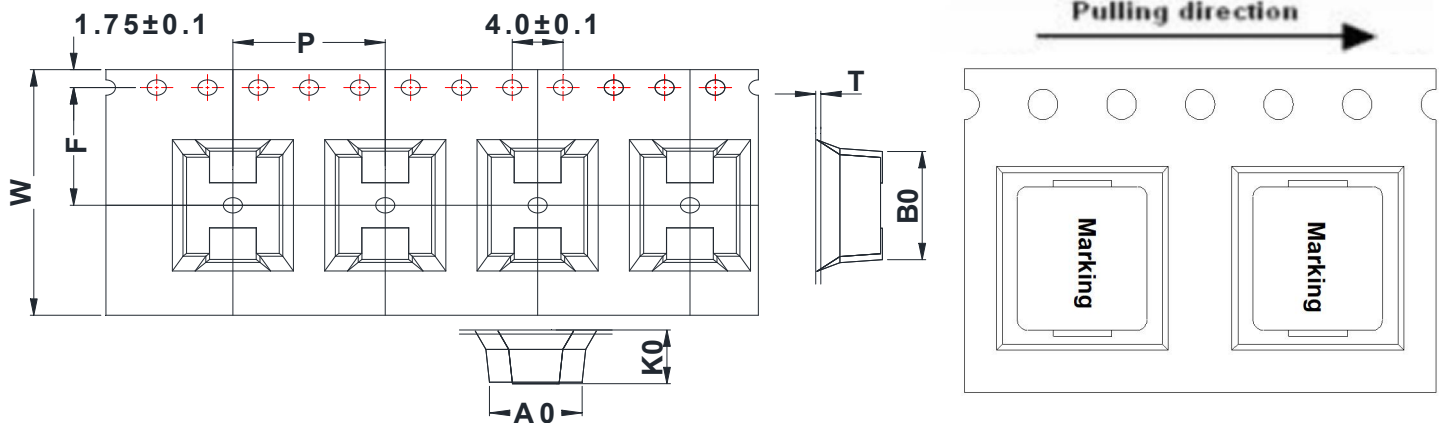
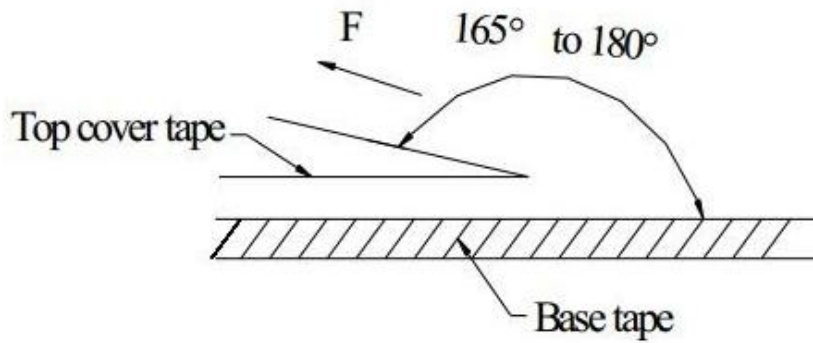
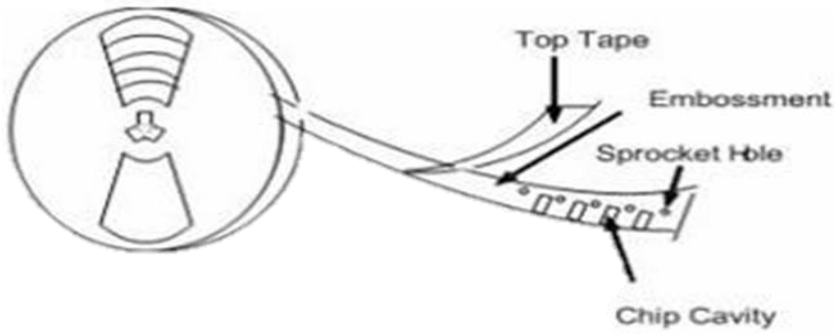

Type	Dimensions (mm)						
	W	P	P0	A0	B0	K0	T
MCMB-1365	24.00 ± 0.30	16.00 ± 0.10	4.00 ± 0.10	13.4 ± 0.1	14.9 ± 0.1	7.30 ± 0.1	0.40 ± 0.05

- Reel Dimensions (UNIT:mm)

Label

Label on the reel

- Customer's part Number
- Lot Number
- Quantity
- date cod

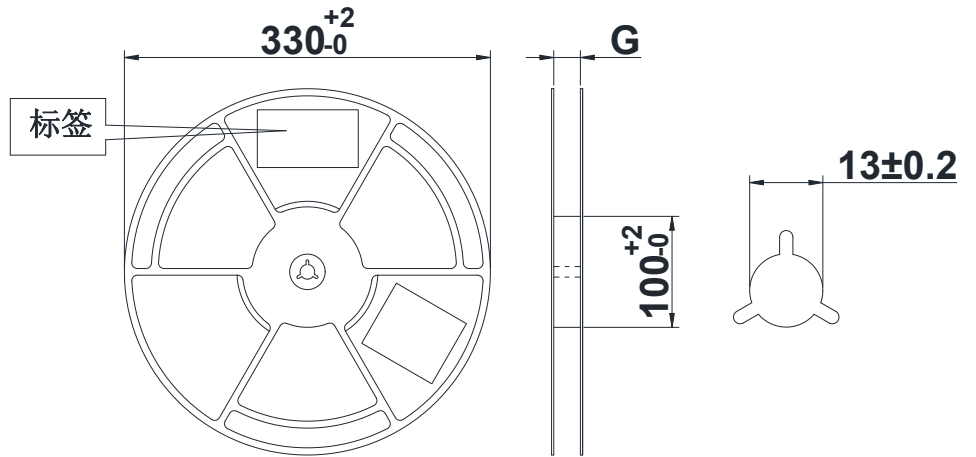

- Packaging Quantity:500PCS/Reel