

MNR6028S Series

Wire Wound SMD Power Inductors

FEATURES

- Magnetic-resin shielded construction reduces buzz noise to ultra-low levels
- Metallization on ferrite core results in excellent shock resistance and damage-free durability
- Closed magnetic circuit design reduces leakage flux and Electro Magnetic Interference (EMI)
- 30% higher current rating than conventional inductors of equal size
- Takes up less PCB real estate and save more power
- Operate temperature range $-40^{\circ}\text{C} \sim +125^{\circ}\text{C}$ (Including self temp. rise)
- RoHS compliant



APPLICATIONS

- Smart phone, smart TV, set top box, notebook
- Car navigation systems, telecomm base stations
- VR, AR
- LED lighting

Explanation of Part Number

MNR 6028 S 1R0 M T

1 2 3 4 5 6

- ◆ 1:Product Series:Wire Wound SMD Power Inductors
- ◆ 2:Dimensions:
- ◆ 3: Feature Type:S Type
- ◆ 4: Initial inductance value: 1R0 = 1.0uH
- ◆ 5: Tolerance of Inductance:M: $\pm 20\%$, N: $\pm 30\%$
- ◆ 6:Packing:Tape Carrier Package

Dimensions: [mm]

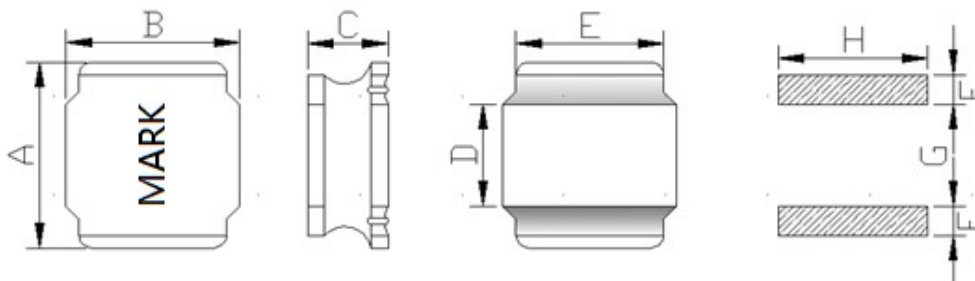

| | |
|---|----------|
| A | 6.00±0.3 |
| B | 6.00±0.3 |
| C | 2.8Max. |
| D | 2.5±0.3 |
| E | 4.9Ref |
| F | 2.0Ref |
| G | 2.4Ref |
| H | 5.7Ref |

Electrical Characteristics List

| Part NO. | Inductance(μH) | Test Freq. (kHz/v) | DC Max (Ω) | Isat (A)Max | Irms (A)Max |
|---------------|-----------------------------|-----------------------|---------------------|-------------|-------------|
| MNR6028S681MT | 680 \pm 20% | 100/1 | 3.90 | 0.28 | 0.26 |

※1: All test data is referenced to 20°C ambient;

※2: Rated current: Isat or Irms, whichever is smaller;

※*3: Isat: DC current at which the inductance drops approximate 30% from its value without current;

※*4: Irms: DC current that causes the temperature rise ($\Delta T = 40^\circ\text{C}$) from 20°C ambient.

Structure (The structure of product.)

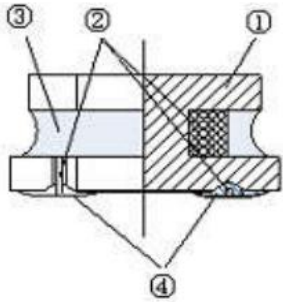

| NO | Components | Material |
|----|---------------|--|
| ① | Core | Ni-Zn Ferrite |
| ② | Wire | Polyurethane system enameled copper wire |
| ③ | Magnetic Glue | Epoxy resin and magnetic powder |
| ④ | Plating | AgNiSn or FeNiCu + Sn Alloy |

Reliability Test

| TEST ITEM | SPECIFICATION | TEST CONDITION |
|---------------------------------------|---|--|
| Withstanding voltage test | After test, inductors shall have no evidence of electrical and mechanical damage. | AC voltage of 100v and AC current of 1mA applied between inductor's terminal and core for 3 secs. |
| Resistance to soldering heat | <ol style="list-style-type: none"> 1. Inductor shall have no evidence of electrical and mechanical damage. 2. Inductance shall not change more than $\pm 5\%$. 3. Q shall not change more than 20%. | <ol style="list-style-type: none"> a. Temp: 260 ± 5 b. Time: 10 ± 1.0 se |
| Solderability test | The terminal shall be at least 95% covered with solder. | After fluxing, the terminal shall be dipped in a melted solder bath at $245 \pm 5^\circ\text{C}$ for 4 ± 1.0 secs. |
| High temperature & high humidity test | The anti-erosion quality of the surface and the specimen's inductance shall not change from the initial value within $\pm 10\%$ | <ol style="list-style-type: none"> a. Test condition <ol style="list-style-type: none"> 1)Temp.: 85°C, R.H.:85% 2)Time: 144 ± 2 hours b. Measurement method The experimental component should be put at normal condition for 2 hours then to measure again after test |
| Salt spray test | | <ol style="list-style-type: none"> a. Test condition <ol style="list-style-type: none"> 1)Temp.: $35 \pm 2^\circ\text{C}$ 2)Time: 48 ± 2 hours 3)Salt solution PH: 6.5~7.2 b. Measurement method The experimental component should be put at normal condition for 2 hours then to measure again after test |
| Vibration test | <ol style="list-style-type: none"> 1. Inductance shall be within 10% of the initial value. 2. Appearance: no damage | <ol style="list-style-type: none"> a. Frequency: 10 to 55 b. Amplitude: 1.5 c. Direction and time X, Y and Z directions for 2 hours each. |

| TEST ITEM | SPECIFICATION | TEST CONDITION |
|----------------------------------|--|--|
| Free fall test | No mechanical damage shall be noticed. | Drop 5 times on a concrete floor from 1m the height |
| Temperature Cycling test | 1. Inductance shall be within 10% of the initial value 2. Appearance: No dama | a. Test conditi 1)Temp.: -55°C ,time: $30\pm 3\text{min}$ 2)Temp.: $+125^{\circ}\text{C}$,time: $30\pm 3\text{min}$ 3)Cycles times:12 cycles b. Measurement method The experimental component should be put at normal condition for 2 hours then to measure again after test |
| High Temperature resistance test | | a. Test conditi 1)Applied rated current 2)Temp.: $85^{\circ}\text{C}\pm 2^{\circ}\text{C}$ 3)Test time: $1000+24/-0\text{H}$ b. Measurement method The experimental component should be put at normal condition for 24 hours then to measure again after test. |
| Low temperature resistance test | | a. Test conditi 1)Temp.: $-55^{\circ}\text{C}\pm 2^{\circ}\text{C}$ 2)Test time: $1000+24/-0\text{H}$ b. Measurement method The experimental component should be put at normal condition for 24 hours then to measure again after test. |

We have suggested the storage period of lead-free product should not over 6 months.

Packaging

1) Tape packing diagram

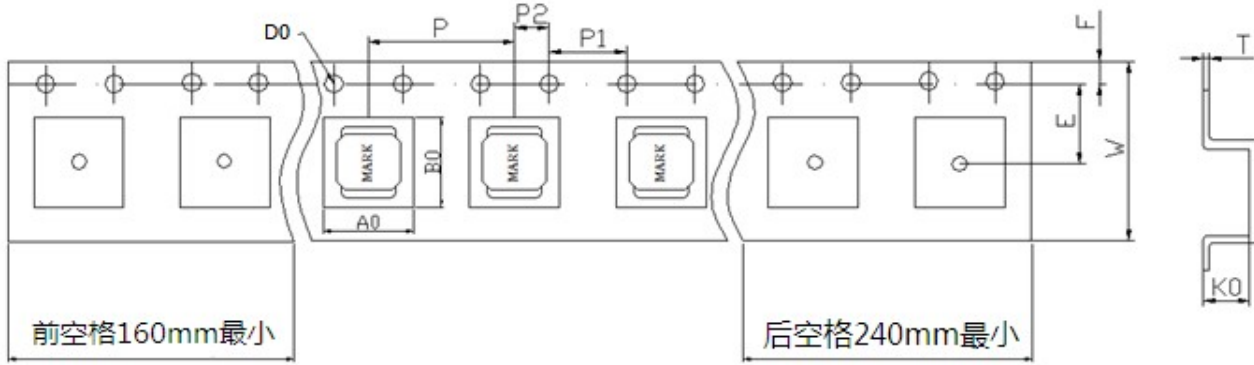

| ITEM | W | A0 | B0 | K0 | P | E | F | D0 | P0 | P2 | T |
|------|-------|------|------|------|------|------|------|------|------|------|-------|
| DIM | 12.00 | 6.30 | 6.30 | 3.00 | 8.00 | 7.50 | 1.75 | 1.50 | 4.00 | 2.00 | 0.35 |
| TOLE | ±0.3 | ±0.1 | ±0.1 | ±0.1 | ±0.1 | ±0.1 | ±0.1 | +0.1 | ±0.1 | ±0.1 | ±0.05 |

2) Tape packing diagram

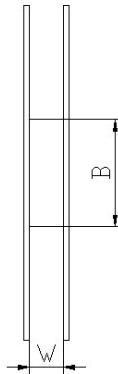
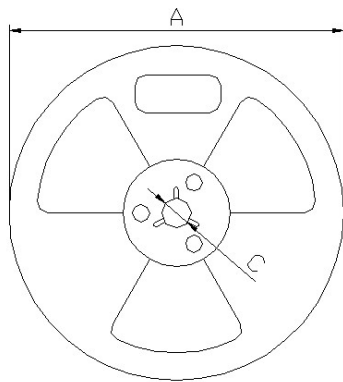

| | |
|---|----------|
| A | 330±0.5 |
| B | 100±0.5 |
| C | 13.5±0.5 |
| W | 12.5±0.5 |

3) Tape packing diagram

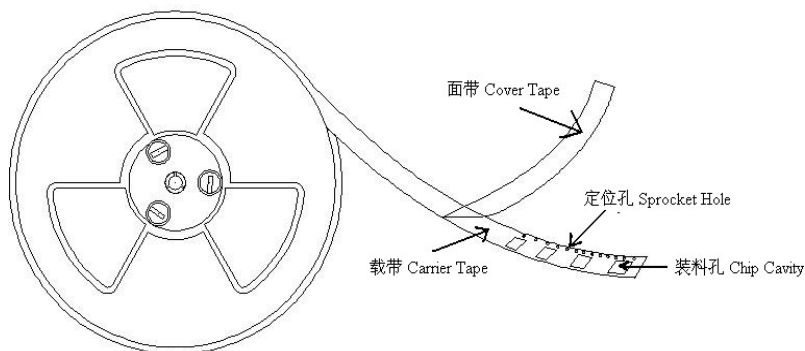

Packaging Quantity: 2000pcs/Reel

SOLDERING CONDITIONS

1. Reflow Soldering Profile



2. Soldering Iron

Reworking with electric soldering iron must preheating at 150°C for 1 minute is required, and do not directly touch the core with the tip of the soldering iron. The reworking soldering conditions are as follows.

- ① Temperature of soldering iron tip: 350 °C;
- ② Soldering iron power output: ≤ 30W;
- ③ Diameter of soldering iron end: ≤ 1.0mm;
- ④ Soldering time: < 3 s

