

NRS3012T Series

Metal Alloy Wire Wound SMD Power Inductors

FEATURES

- Fe base metal material core provides large saturation current
- Metallization on ferrite core results in excellent shock resistance and damage-free durability
- Closed magnetic circuit design reduces leakage flux and Electro Magnetic Interference (EMI)
- Low DCR decreases power loss, small and slim take up less PCB real estate
- Automatic production ensures high quality and consistency
- Operate temperature range $-40^{\circ}\text{C} \sim +125^{\circ}\text{C}$ (Including self temp. rise)
- RoHS compliant

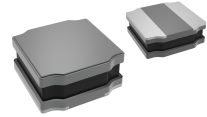

APPLICATIONS

- Smart phone, set top box, VR, AR
- Notebooks, desktop computers, servers
- Portable gaming devices, personal navigation systems, personal multimedia devices

Explanation of Part Number

NRS 3012 T 1R0 M T
 1 2 3 4 5 6

- ◆ 1:Product Series: Metal Alloy Wire Wound SMD Power Inductors
- ◆ 2:Dimensions:
- ◆ 3: Feature Type:T Type
- ◆ 4: Initial inductance value: 1R0 = 1.0uH
- ◆ 5: Tolerance of Inductance:M: $\pm 20\%$, N: $\pm 30\%$
- ◆ 6:Packing:Tape Carrier Package

SHAPE AND DIMENSIONS [mm]

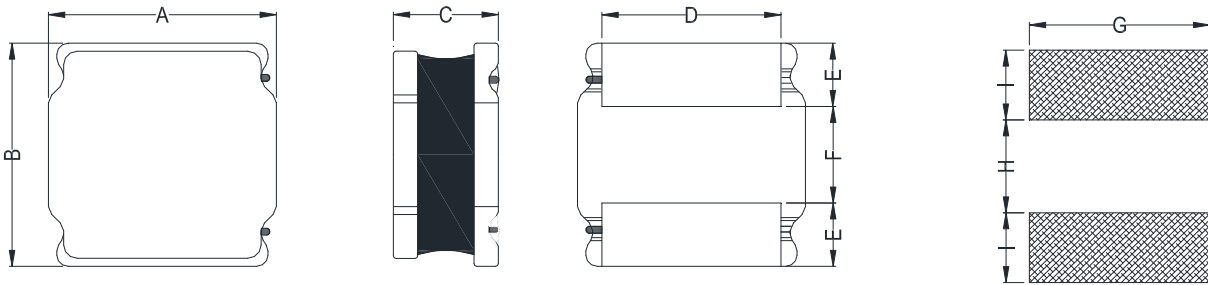

Recommended Land Pattern

A	B	C	D	E	F	G	H	I
3.0 ± 0.2	3.0 ± 0.2	1.2Max	2.3 ± 0.3	1.0 ± 0.3	1.0 ± 0.3	2.7	1.5	0.8

Electrical Characteristics List

NRS3012T Series

Part Number	Inductance	DC Resistance		Saturation Current		Heat Rating Current	
	1MHz/1V	Max.	Typ.	Max.	Typ.	Max.	Typ.
Units	uH	Ω	Ω	A	A	A	A
Symbol	L	DCR		Isat		Irms	
NRS3012TR22MT	0.22 ± 20%	0.026	0.020	9.30	10.0	4.20	4.80
NRS3012TR33MT	0.33 ± 20%	0.032	0.024	7.20	8.90	4.10	4.80
NRS3012TR47MT	0.47 ± 20%	0.040	0.031	6.80	8.00	3.80	4.20
NRS3012TR68MT	0.68 ± 20%	0.046	0.038	5.80	6.80	3.10	3.60
NRS3012T1R0MT	1.0 ± 20%	0.054	0.046	4.20	5.40	2.70	3.10
NRS3012T1R5MT	1.5 ± 20%	0.074	0.062	3.40	4.10	2.50	2.90
NRS3012T2R2MT	2.2 ± 20%	0.108	0.090	2.80	3.35	2.05	2.35
NRS3012T3R3MT	3.3 ± 20%	0.185	0.144	2.20	2.60	1.50	1.80
NRS3012T4R7MT	4.7 ± 20%	0.255	0.215	2.00	2.50	1.15	1.35
NRS3012T6R8MT	6.8 ± 20%	0.340	0.290	1.60	1.90	1.10	1.25
NRS3012T100MT	10 ± 20%	0.474	0.395	1.20	1.45	1.00	1.15
NRS3012T150MT	15 ± 20%	0.740	0.610	1.10	1.30	0.53	0.60
NRS3012T220MT	22 ± 20%	1.20	0.960	0.96	1.15	0.40	0.46

※1: All test data is referenced to 20°C ambient;

※2: Rated current: Isat or Irms, whichever is smaller;

※3: For WPN3012 size inductors, absolute maximum voltage: DC 40V;

※Isat: DC current at which the inductance drops approximate 30% from its value without current;

※Irms: DC current that causes the temperature rise ($\Delta T = 40^\circ \text{C}$) from 20° C ambient.

TYPICAL ELECTRICAL CHARACTERISTICS

Temperature vs. DC Current Characteristics

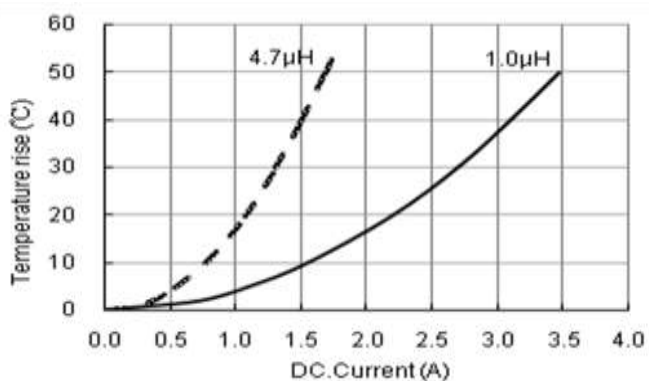

Inductance vs. DC Current Characteristics

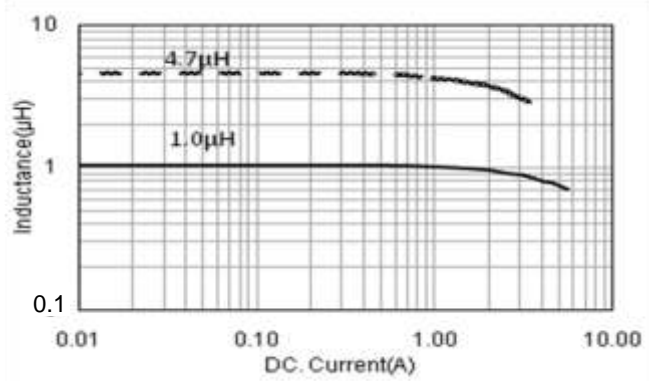

Reliability Test

TEST ITEM	SPECIFICATION	TEST CONDITION
Withstanding voltage test	After test, inductors shall have no evidence of electrical and mechanical damage.	AC voltage of 100v and AC current of 1mA applied between inductor's terminal and core for 3 secs.
Resistance to soldering heat	1. Inductor shall have no evidence of electrical and mechanical damage. 2. Inductance shall not change more than $\pm 5\%$. 3. Q shall not change more than 20%.	a. Temp: 260 ± 5 b. Time: 10 ± 1.0 se
Solderability test	The terminal shall be at least 95% covered with solder.	After fluxing, the terminal shall be dipped in a melted solder bath at $245 \pm 5^\circ\text{C}$ for 4 ± 1.0 secs.
High temperature & high humidity test	The anti-erosion quality of the surface and the specimen's inductance shall not change from the initial value within $\pm 10\%$	a. Test conditions 1)Temp.: 85°C , R.H.:85% 2)Time: 144 ± 2 hours b. Measurement method The experimental component should be put at normal condition for 2 hours then to measure again after test
Salt spray test		a. Test conditions 1)Temp.: $35 \pm 2^\circ\text{C}$ 2)Time: 48 ± 2 hours 3)Salt solution PH:6.5~7.2 b. Measurement method The experimental component should be put at normal condition for 2 hours then to measure again after test
Vibration test	1. Inductance shall be within 10% of the initial value. 2. Appearance: no damage	a. Frequency: 10 to 55 b. Amplitude: 1.5 c. Direction and time X, Y and Z directions for 2 hours each.

TEST ITEM	SPECIFICATION	TEST CONDITION
Free fall test	No mechanical damage shall be noticed.	Drop 5 times on a concrete floor from 1m the height
Temperature Cycling test	1. Inductance shall be within 10% of the initial value 2. Appearance: No dama	a. Test conditi 1)Temp.: -55°C ,time: $30\pm 3\text{min}$ 2)Temp.: $+125^{\circ}\text{C}$,time: $30\pm 3\text{min}$ 3)Cycles times:12 cycles b. Measurement method The experimental component should be put at normal condition for 2 hours then to measure again after test
High Temperature resistance test		a. Test conditi 1)Applied rated current 2)Temp.: $85^{\circ}\text{C}\pm 2^{\circ}\text{C}$ 3)Test time: $1000+24/-0\text{H}$ b. Measurement method The experimental component should be put at normal condition for 24 hours then to measure again after test.
Low temperature resistance test		a. Test conditi 1)Temp.: $-55^{\circ}\text{C}\pm 2^{\circ}\text{C}$ 2)Test time: $1000+24/-0\text{H}$ b. Measurement method The experimental component should be put at normal condition for 24 hours then to measure again after test.

We have suggested the storage period of lead-free product should not over 6 months.

Structure

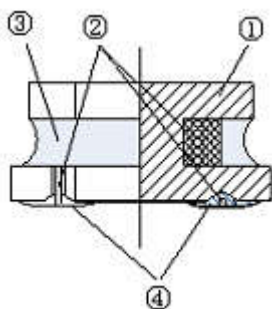

NO.	Components	Material
①	Core	Soft magnetic Metal
②	Wire	Polyurethane system enameled copper wire
③	Magnetic Glue	Epoxy resin and magnetic powder
④	Electrodes	AgNiSn or FeNiCu + Sn Alloy

Packaging and Marking:

Carrier Tape Dimensions:

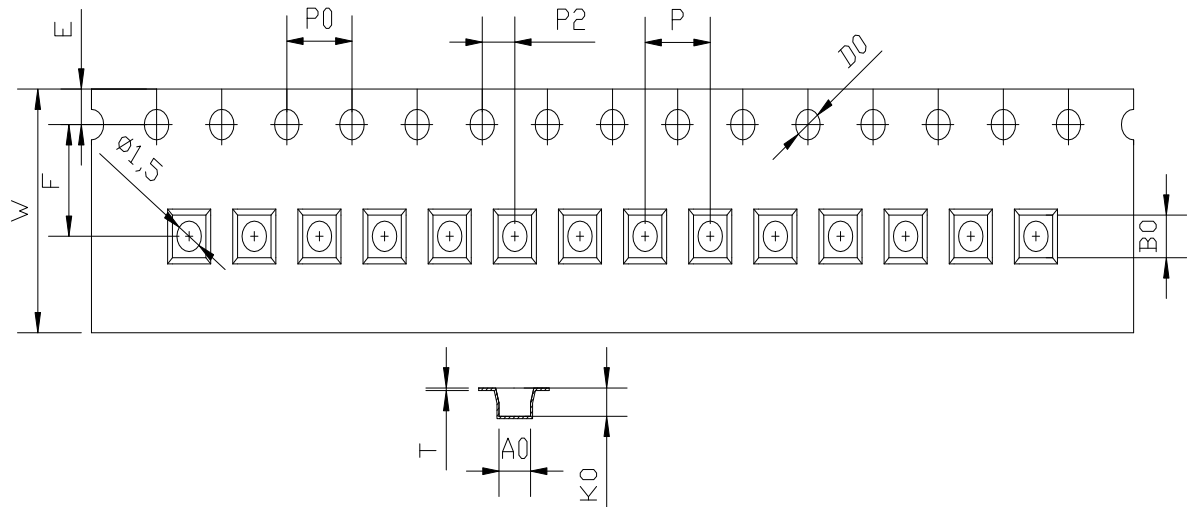

ITEM	W	A0	B0	K0	P	F	E	D0	P0	P2	T
DIM	8.00	3.3	3.3	1.6	4.00	3.50	1.75	1.50	4.00	2.00	0.25
TOLE	±0.1	±0.05	±0.05	±0.1	±0.1	±0.1	±0.1	+0.1	±0.1	±0.1	±0.05

Reel Dimensions:

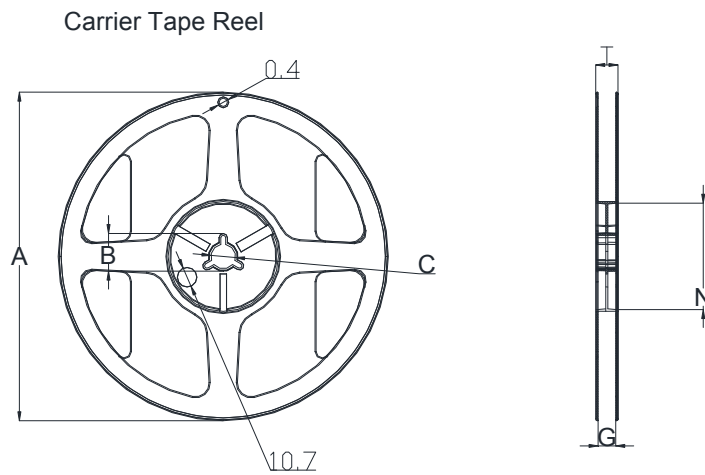

Type	A	B	C	G	N	T
8mm	178	20.7±0.8	13±0.4	9	60	10.8

Packaging Quantity: 2KPCS/ Reel

Re-flowing Profile:

